



COVAL

vacuum managers

FlowPack Suction Cups

FPC

series



FPC Series: Universal

A Collection of Innovations

The shape of the lip has been designed to match the deformation of flexible packaging and ensure the best possible seal during positioning; which, as an additional advantage, allows for a reduction in power of the vacuum generator. The FPC suction cups are also equipped with cleats that stiffen the lip and reinforce the clamping effect.

- ❶ **Thin and wavy flower-shaped lips** that perfectly mold to the packaging, whatever the shape.
- ❷ **Internal cleats** that allow for optimized vacuum while preventing any crushing and also strengthen the hold on the product being handled.
- ❸ **Fittings featuring a lateral vacuum distributor** that prevent any loss in efficiency when the product is held.
- ❹ **Materials: Food-grade** silicone and plastic insert meets FDA and CE standards.



*Focusing on the needs of its customers in the food industry, **COVAL**, a company certified **ISO 9001: V2015**, has developed a series of particularly innovative silicone cups, dedicated to the high-speed handling of flexible packaging.*

*Combining great flexibility and food compatibility, the new **FPC Series** suction cups have been specially designed to optimize the handling of packed bags from **100 g to 5 kg**. E.g. - **FlowPack, DoyPack**, etc.*

Advantages

WITHSTANDS HIGH PRODUCTION RATES:

- Its gripping ability allows for high production rates.
- No interruption in the packaging line due to faulty gripping.

SAFETY:

- The FPC Series suction cup is made of silicone, a material that is recommended for its temperature resistance and food safety. The plastic fittings also conform to food standards.

ENERGY SAVINGS:

- The airtightness of FPC Series suction cups avoids the need for an oversized vacuum generator, allowing for considerable energy savings.

SUITABLE FOR ALL FLOWPACKS:

- Different forms and dimensions for a suitable solution.

A Complete Range

AVAILABLE IN FOUR SIZES:

- Round, Ø 35 mm, 1.5 bellows.
- Round, Ø 45 and 60 mm.
- Elliptical, 120 x 100 mm.

TWO LEVELS OF FLEXIBILITY:

- 35 and 50 Shore.

MATERIALS:

FPC suction cups are compatible with FDA food standards (FDA 21 CFR 177.2600.) and meet the European regulation (EC) 1935/2004.

- **Suction cups:** Silicone.
- **Fittings:** Plastic POM-C and PETP.
- **Flat Seal:** Silicone.
- **Screw:** Stainless Steel.



FPC VIDEO

Discover the FPC suction cups in action!





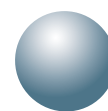

certified quality management system



FlowPack Suction Cups

Characteristics

|  | Dim. (mm) |  (cm ³) |  (N) ⁽¹⁾ | Shore Hardness |  (g) | ØA (mm) | ØD (mm) | L (mm) | l (mm) | f ⁽²⁾ (mm) | H (mm) | H1 (mm) | ØG (mm) | E  |
|---|--------------|--|--|-------------------|---|------------|------------|-----------|-----------|--------------------------|-----------|------------|------------|---|
| FPC351.5SIBL3IF14PC | Ø 35 | 7.2 | 5 | 35 | 9.9 | 35 | 23 | / | / | 10 | 29 | 36 | G1/4"-F | 19 |
| FPC351.5SIBL5IF14PC | Ø 35 | 7.2 | 5 | 50 | 9.9 | 35 | 23 | / | / | 10 | 29 | 36 | G1/4"-F | 19 |
| FPC45SIBL3IF38PC | Ø 45 | 13 | 10 | 35 | 20 | 45 | 39 | / | / | 7 | 23 | 30 | G3/8"-F | 26 |
| FPC45SIBL5IF38PC | Ø 45 | 13 | 10 | 50 | 20 | 45 | 39 | / | / | 7 | 23 | 30 | G3/8"-F | 26 |
| FPC60SIBL3IF38PC | Ø 60 | 24.5 | 15 | 35 | 21.5 | 60 | 40 | / | / | 10 | 26 | 33 | G3/8"-F | 26 |
| FPC60SIBL5IF38PC | Ø 60 | 24.5 | 15 | 50 | 21.5 | 60 | 40 | / | / | 10 | 26 | 33 | G3/8"-F | 26 |
| FPC120100SIBL3IF38P1V | 120x100 | 167 | 50 | 35 | 92.1 | / | / | 120 | 100 | 15 | 32.5 | 42.5 | G3/8"-F | / |
| FPC120100SIBL5IF38P1V | 120x100 | 167 | 50 | 50 | 92.1 | / | / | 120 | 100 | 15 | 32.5 | 42.5 | G3/8"-F | / |

(1) Force measured at 65% vacuum, without safety factor.

(2) f = deflection of the suction cup.

Dimensions "Suction Cup + Fitting"

FPC351.5...IF14PC

Round, Ø 35 mm, 1.5 bellows

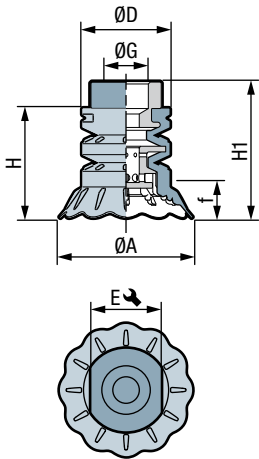

FPC45...IF38PC FPC60...IF38PC

Round, Ø 45 and 60 mm

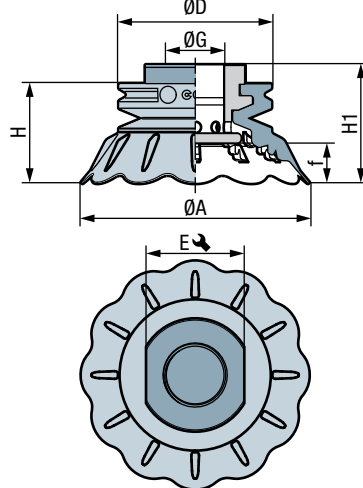

FPC120100...IF38P1V

Elliptical, 120 x 100 mm

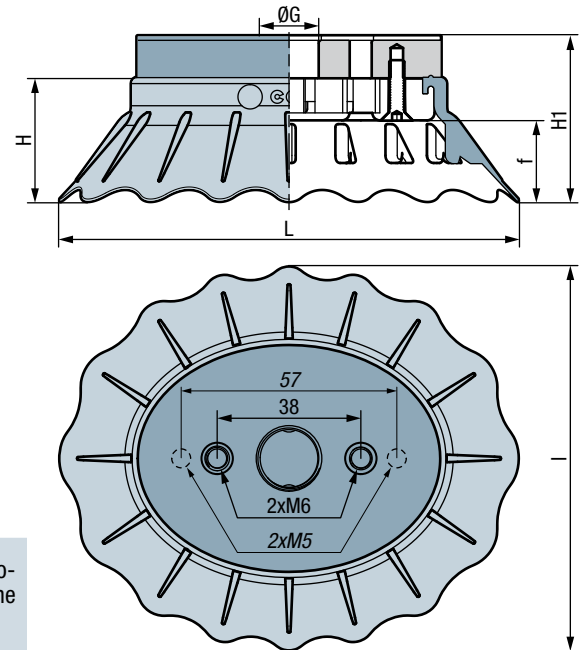

**3D
COVAL Data**

On our site www.coval.com you will find 3D models of all our products, in formats suitable for the principal CAD software.

Mounting Configurations

FPC351.5/FPC45/FPC60

Via connection:

- FPC351.5 : G 1/4"-F
- FPC45/FPC60 : G 3/8"-F



FPC120100

From below:

- 2 M5x20 screws(not included).



From above:

- 2 M6x16 screws(not included).

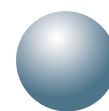

FPC Series: Universal

To Order:

FPC351.5 Round, Ø 35 mm, 1.5 bellows

COMPLETE PART CONFIGURATION

- SUCTION CUP
- + UPPER G1/4"-F FITTING
- + LOWER PLATE:

- Hardness 35 Shore
FPC351.5SIBL3IF14PC
- Hardness 50 Shore
FPC351.5SIBL5IF14PC



INDIVIDUAL PART REFERENCE

UPPER G1/4"-F FITTING ONLY:
IF14PFPC35

SUCTION CUP ONLY:
▪ Hardness 35 Shore
FPC351.5SIBL3
▪ Hardness 50 Shore
FPC351.5SIBL5

LOWER PLATE ONLY:
IL1PFPC35

FPC45/FPC60 Round, Ø 45 and 60 mm

COMPLETE PART CONFIGURATION

- SUCTION CUP
- + G3/8"-F FITTING:

FPC45

- Hardness 35 Shore
FPC45SIBL3IF38PC
- Hardness 50 Shore
FPC45SIBL5IF38PC

FPC60

- Hardness 35 Shore
FPC60SIBL3IF38PC
- Hardness 50 Shore
FPC60SIBL5IF38PC



INDIVIDUAL PART REFERENCE

G3/8"-F FITTING ONLY:
IF38PFPC60

FPC45
SUCTION CUP ONLY:
▪ Hardness 35 Shore
FPC45SIBL3
▪ Hardness 50 Shore
FPC45SIBL5

FPC60
SUCTION CUP ONLY:
▪ Hardness 35 Shore
FPC60SIBL3
▪ Hardness 50 Shore
FPC60SIBL5

FPC120100 Elliptical, 120 x 100 mm

COMPLETE PART CONFIGURATION

- SUCTION CUP
- + LOWER PLATE
- + UPPER PLATE G3/8"-F
- + FLAT SEAL:

- Hardness 35 Shore
FPC120100SIBL3IF38P1V
- Hardness 50 Shore
FPC120100SIBL5IF38P1V



INDIVIDUAL PART REFERENCE

UPPER PLATE G3/8"-F + FLAT SEAL:
IF38PFPC120

SUCTION CUP ONLY:
▪ Hardness 35 Shore
FPC120100SIBL3
▪ Hardness 50 Shore
FPC120100SIBL5

LOWER PLATE + 2 STAINLESS SCREWS M4x16:
IL1PFPC120

Standard configurations (suction cup + fitting) are delivered unassembled.

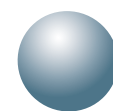

FlowPack Suction Cups



Applications

The FPC series suction cups are dedicated to the handling of flexible packaging such as FlowPack, Doypack, etc.

FlowPack < 0.5 kg: suction cup Ø 35 mm, FPC351.5.

FlowPack < 1 kg: suction cup Ø 45 mm, FPC45.

FlowPack < 1.5 kg: suction cup Ø 60 mm, FPC60.

FlowPack ≤ 5 kg: oval suction cup 120x100 mm, FPC120100.





COVAL
vacuum managers

vacuum components



A TECHNOLOGICAL PARTNER ON A GLOBAL SCALE

Located in the southeast region of France, COVAL conceives, manufactures and globally distributes high performance, advanced vacuum automation components and systems for industrial applications in all branches.

COVAL is an ISO 9001: V2015 certified company which offers innovative solutions integrating reliable and optimized components with intelligent functionalities. The focus is to provide the most personalized and economic solution to a given application while assuring a significant improvement in the productivity and the safety for the vacuum users around the world.

COVAL has an ambition for technical excellence and innovation. As a specialist in vacuum automation, COVAL is reputed for offering reliable, personalized, cost effective and productive solutions.

The references of COVAL can be found in several industrial sectors (Packaging, Automotive Industry, Plastic, Graphic, Aeronautic...) where vacuum handling is important for high efficiency and productivity.

COVAL markets its products and services all over Europe, in the United States and South America through its subsidiaries and authorized distribution network. COVAL strives to provide customer driven solutions and gives the best possible treatment to satisfy all its clients.

For all enquiries from Australia, Africa and Asia kindly contact COVAL head office in France.

Distributed by:



COVAL S.A.S.
Head Office
ZA des Petits Champs
10 allée Jean-Baptiste Venturi
26120 Montélier France
Tel : +33 (0)4 75 59 91 91
Fax : +33 (0)4 75 59 91 05

www.coval.com